



US 20100027382A1

(19) **United States**

(12) **Patent Application Publication**
Daout et al.

(10) **Pub. No.: US 2010/0027382 A1**

(43) **Pub. Date: Feb. 4, 2010**

(54) **HAIRSPRING FOR A BALANCE WHEEL/HAIRSPRING RESONATOR**

(30) **Foreign Application Priority Data**

Jul. 29, 2008 (EP) 08405188.7

(75) Inventors: **Jerôme Daout**, Rolle (CH);
Richard Bossart, Lausanne (CH)

Publication Classification

(51) **Int. Cl.**
G04B 17/06 (2006.01)

(52) **U.S. Cl.** **368/175**

Correspondence Address:
WESTERMAN, HATTORI, DANIELS & ADRIAN, LLP
1250 CONNECTICUT AVENUE, NW, SUITE 700
WASHINGTON, DC 20036 (US)

(57) **ABSTRACT**

Hairspring for a balance wheel/hairspring resonator, comprising n blades, where $n \geq 2$, which are fastened via at least one of their respective homologous ends and wound in spirals with an angular offset capable of neutralizing the lateral forces liable to be exerted on its central arbor when one of the ends of each blade is moved angularly around said central arbor relative to its other end.

(73) Assignee: **ROLEX S.A.**, Geneva (CH)

(21) Appl. No.: **12/511,420**

(22) Filed: **Jul. 29, 2009**

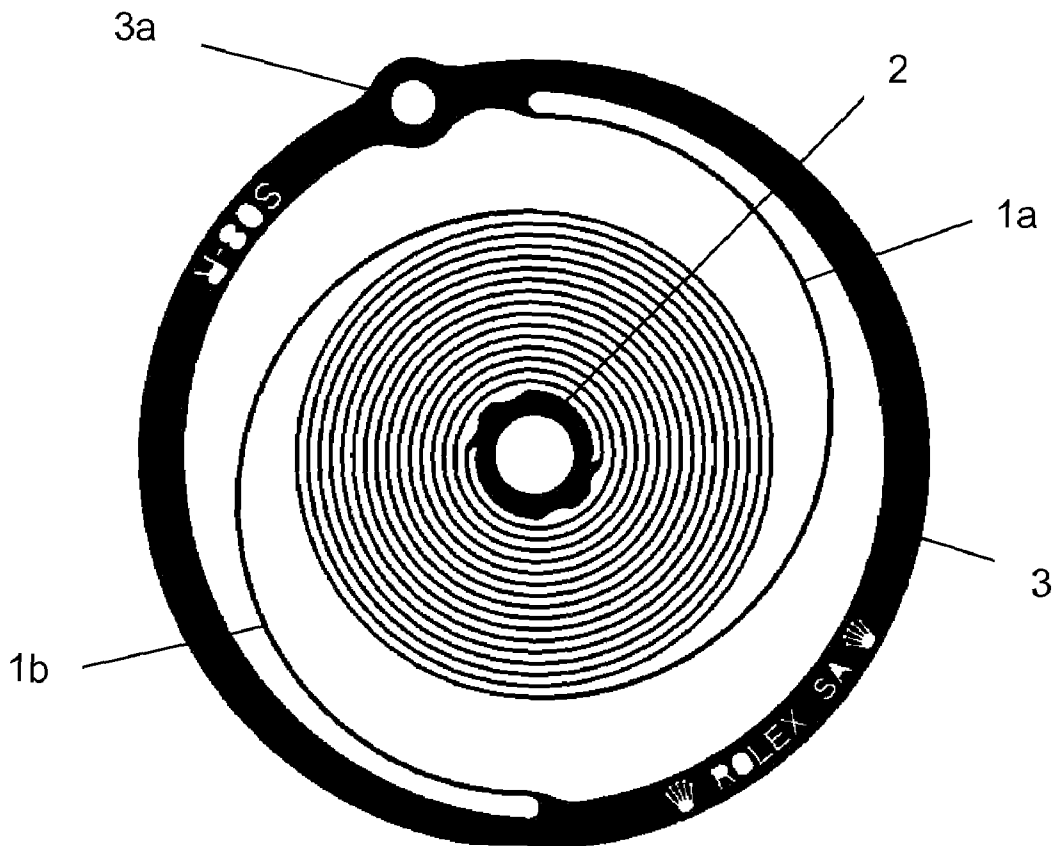

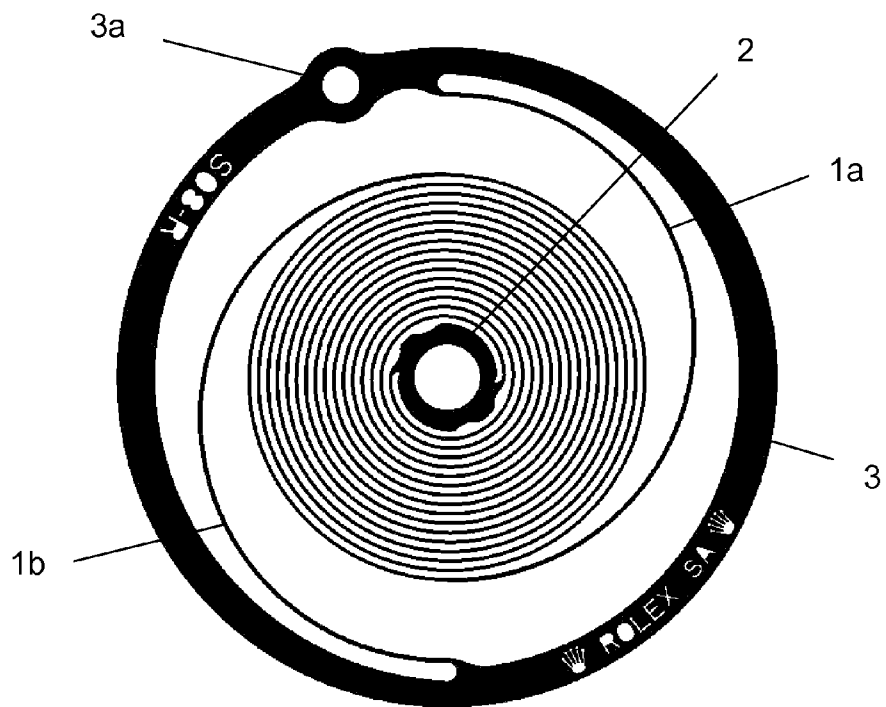

Figure 1

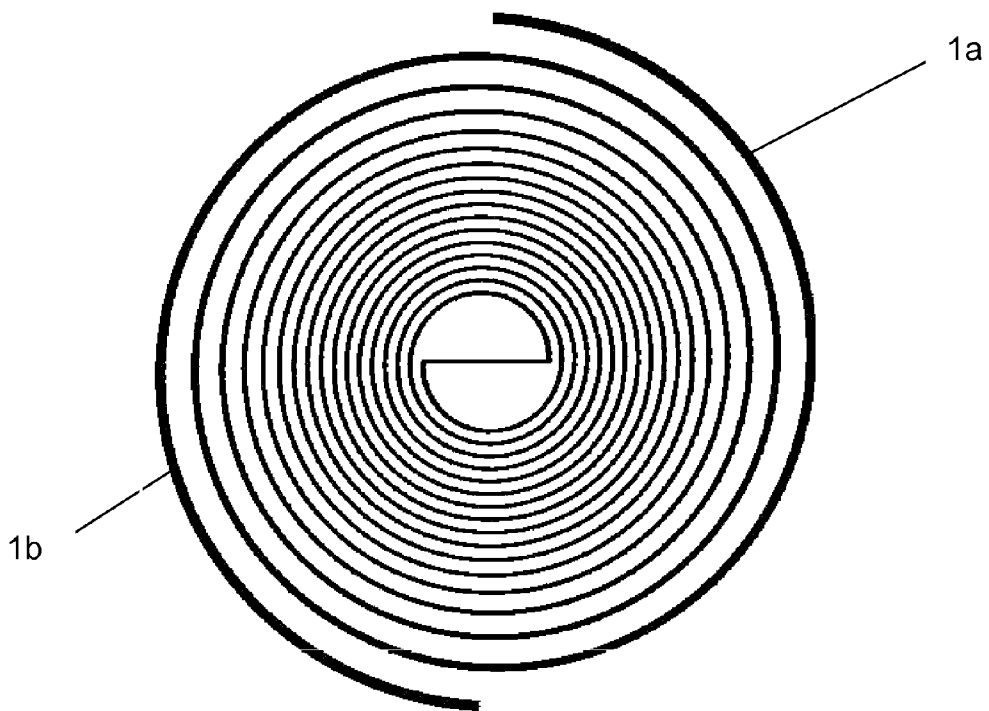

Figure 2

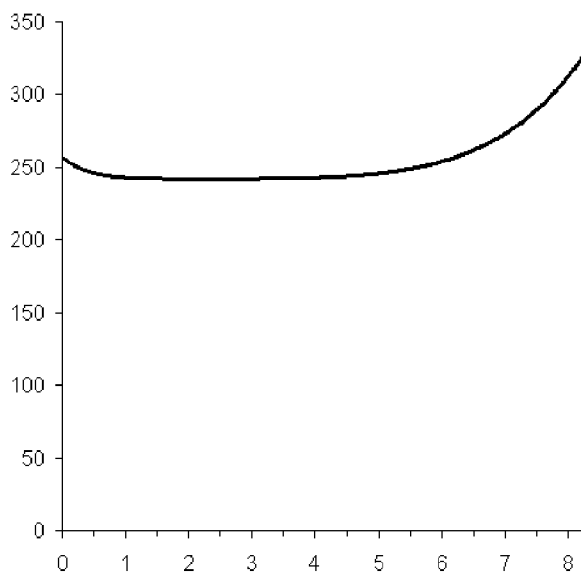

Figure 3

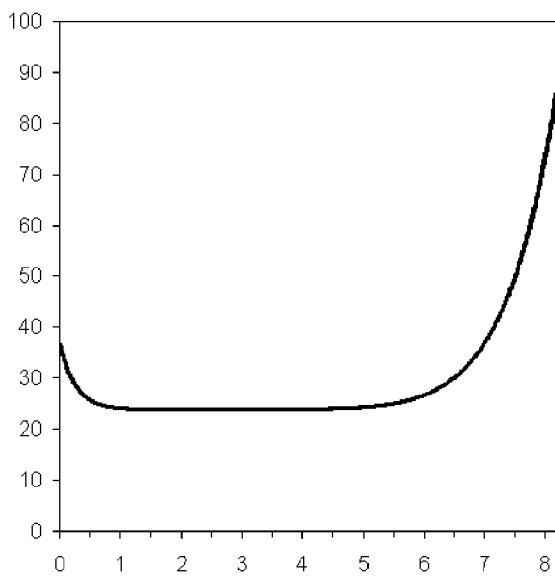

Figure 4

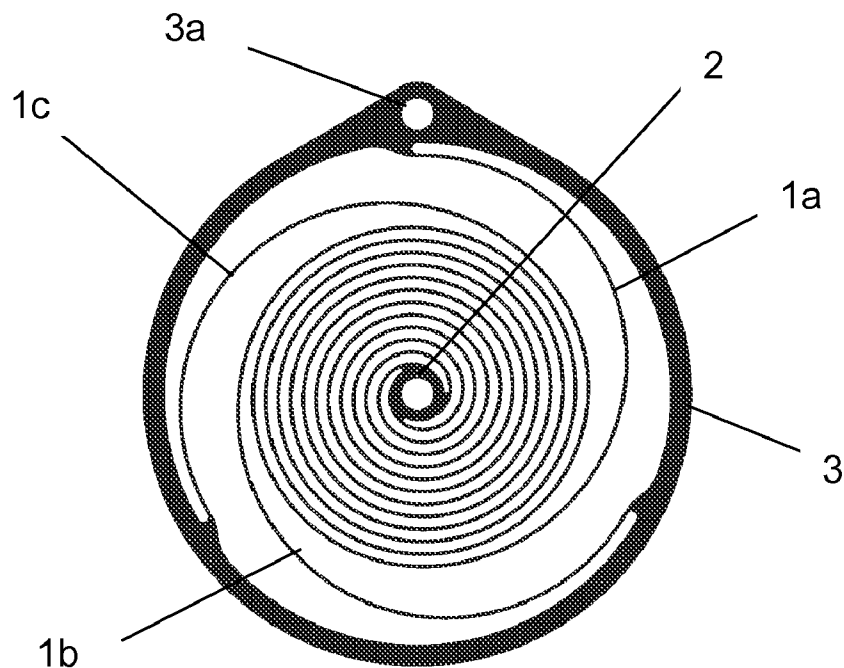

Figure 5

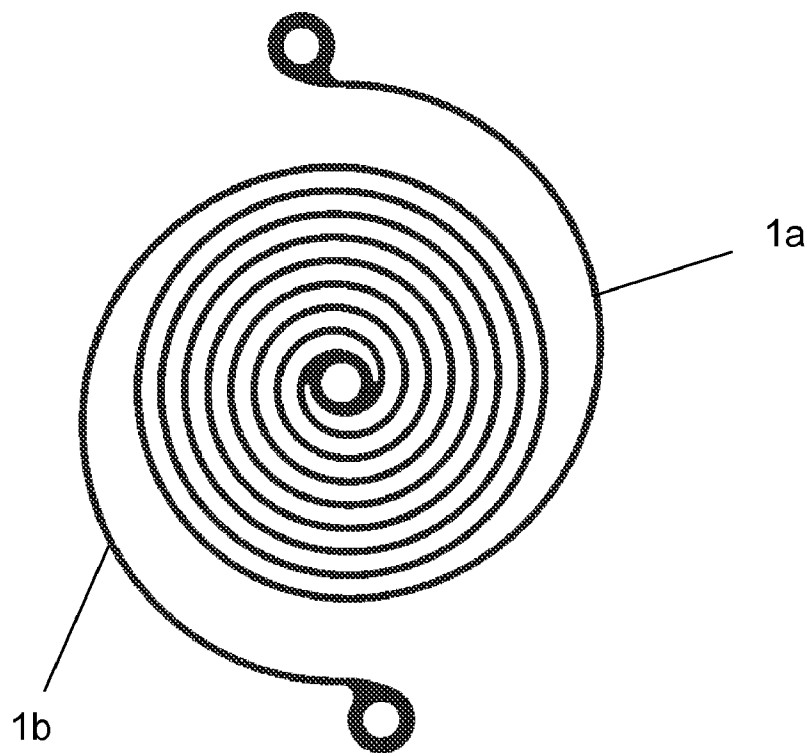

Figure 6

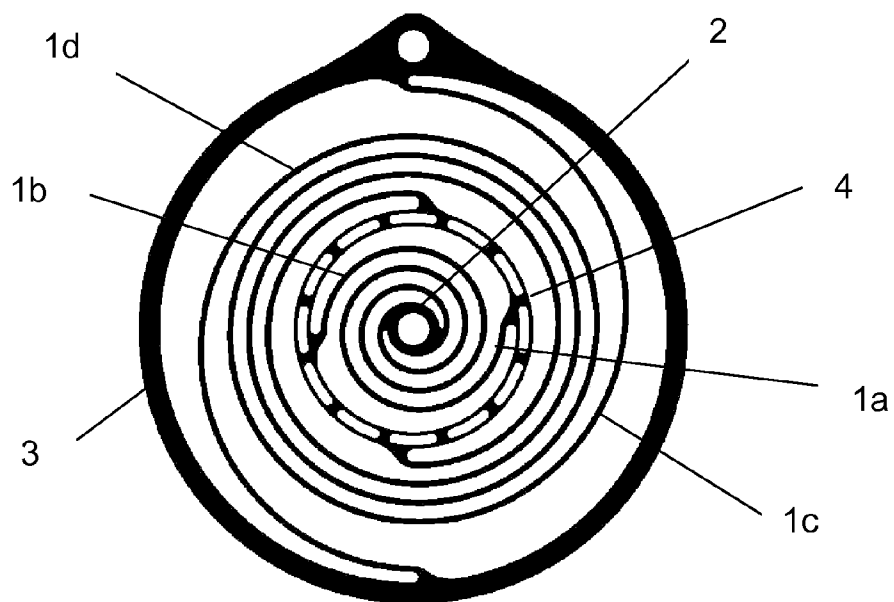

Figure 7

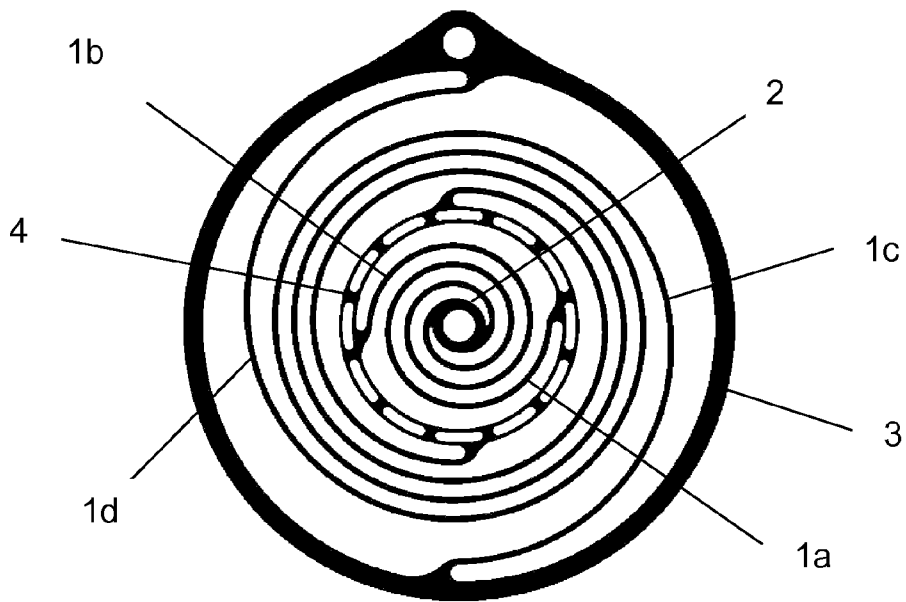

Figure 8

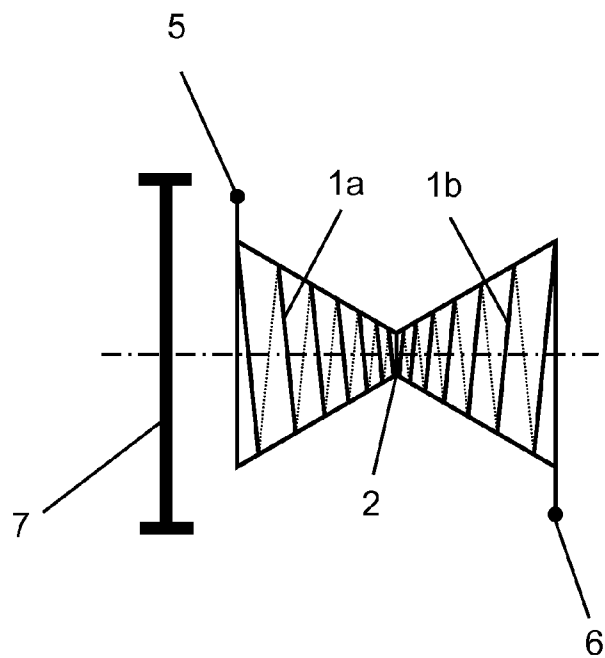

Figure 9

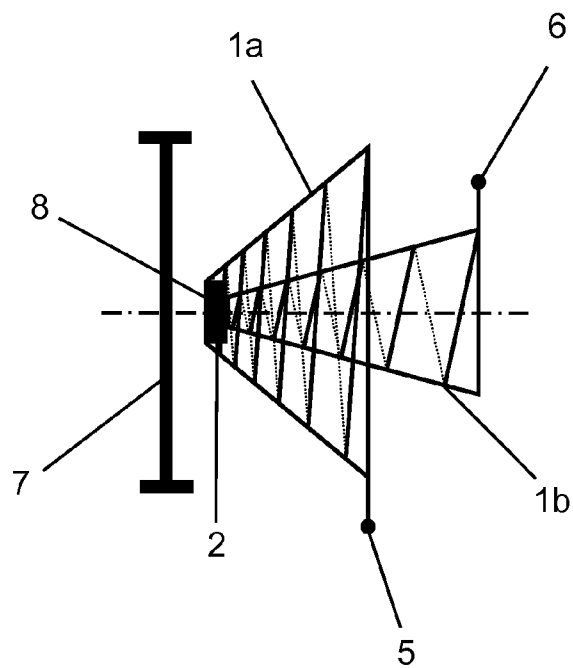

Figure 10a

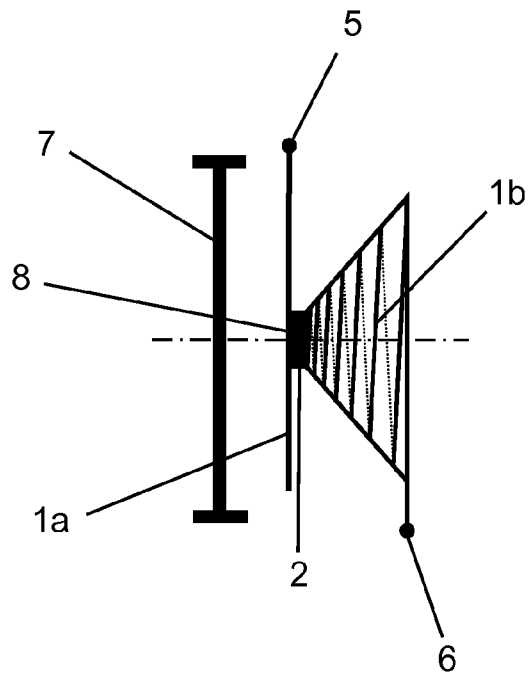

Figure 10b

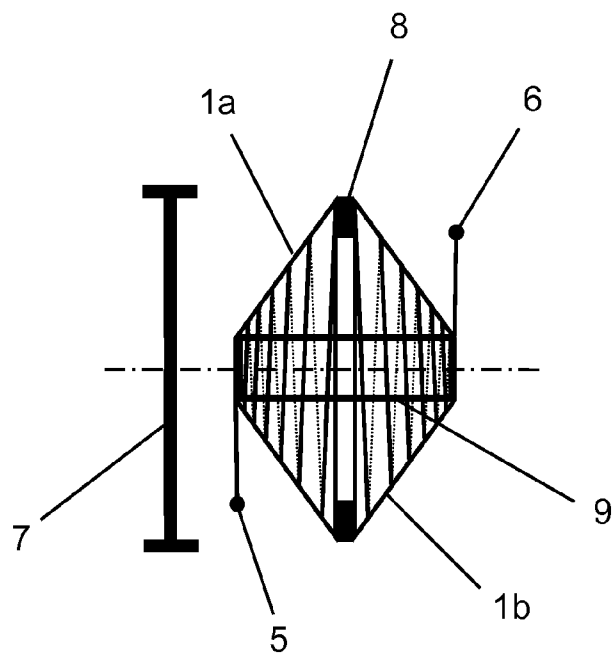

Figure 11

HAIRSPRING FOR A BALANCE WHEEL/HAIRSPRING RESONATOR

BACKGROUND OF THE INVENTION

[0001] The present invention relates to a hairspring for a balance wheel/hairspring resonator.

DESCRIPTION OF THE PRIOR ART

[0002] It is known that the center of gravity of a flat hairspring moves during the oscillatory movement of the balance wheel. This is due to the fact that one of the ends of the hairspring is fixed, whereas the other end moves while still remaining at the same distance from the balance wheel arbor. This displacement of the center of gravity has an influence on the isochronism because it generates lateral forces on the pivots of the balance wheel arbor.

[0003] Abraham-Louis Breguet had the idea of providing the flat hairspring with one or two terminal curves enabling this defect to be remedied. Subsequently, a theoretical treatment of such a curve was published by M. Phillips.

[0004] Before the solution devised by Breguet and Phillips, T. Mudge had proposed the use of two hairsprings fastened to the same balance wheel and offset by 180°. Since the hairsprings work in synchronism, but in phase opposition, the variations in their respective centers of gravity are compensated for, but their axial offset creates, however, a slight torque in a plane containing the balance wheel arbor. This solution has been adopted in recent productions.

[0005] The problem with this solution lies in the fact that it is necessary to have two superposed hairsprings, increasing the height, two studs and two stud carriers that are offset by 180° about the balance wheel arbor, and two regulator pins, and each hairspring must be regulated in perfect synchronism with the other, leading to an extremely complex solution difficult to implement. In addition, it doubles the number of components.

[0006] This solution has been adopted in several publications, especially in U.S. Pat. No. 3,553,956, in FR 2 447 571 and in CN 1 677 283.

[0007] The object of the present invention is to benefit from the advantages of this solution while remedying, at least in part, the abovementioned drawbacks.

SUMMARY OF THE INVENTION

[0008] For this purpose, the subject of the present invention is a hairspring for a balance wheel/hairspring resonator as claimed in claim 1.

BRIEF DESCRIPTION OF THE DRAWINGS

[0009] The appended drawings illustrate schematically, and by way of example, several embodiments of the hairspring forming the subject of the present invention:

[0010] FIG. 1 is a plan view of a first embodiment;

[0011] FIG. 2 is a plan view of a second embodiment;

[0012] FIG. 3 is a graph showing the variation of the hairspring pitch plotted as a function of the number of turns from the center outwards in the case of the embodiment shown in FIG. 2;

[0013] FIG. 4 is a graph showing the variation in the thickness along the blade plotted as a function of the number of turns from the center outwards in the case of the embodiment shown in FIG. 2;

[0014] FIG. 5 is a plan view of a third embodiment;

[0015] FIG. 6 is a plan view of a fourth embodiment;

[0016] FIG. 7 is a plan view of a fifth embodiment;

[0017] FIG. 8 is a plan view of a sixth embodiment;

[0018] FIG. 9 is a side view of a seventh embodiment;

[0019] FIGS. 10a and 10b are side views of two variants of an eighth embodiment; and

[0020] FIG. 11 is a side view of a ninth embodiment.

DESCRIPTION OF THE PREFERRED EMBODIMENTS

[0021] The first embodiment of the hairspring forming the subject of the invention is illustrated in FIG. 1. This flat hairspring comprises two blades 1a, 1b wound in the same direction, but with an offset of $2\pi/2$, i.e. 180°. The respective internal ends of these blades 1a, 1b are fastened to a bushing 2 and their external ends are fastened to a fastening ring 3. These external ends are also angularly offset by 180°. The fastening ring 3 to which the external ends of the blades 1a, 1b of the hairspring are fastened has an opening 3a for fastening it to the balance wheel bridge. This fastening ring 3 therefore replaces the conventional stud.

[0022] The two blades 1a, 1b of the hairspring must not touch each other as they contract and expand. The risk of so doing increases with the amplitude. Therefore, this can be reduced by limiting the amplitude. However, it may be also advantageous to increase the diameter of the hairspring.

[0023] Yet another solution is that which consists in varying the pitch of the turns and varying the thickness of the blades. This is shown by the embodiment in FIG. 2, and also the graphs of FIGS. 3 and 4 which illustrate the variation in the pitch of the turns in microns and the variation in the thickness of the blades in microns, respectively, as a function of the number of turns N_t of the wound blades 1a, 1b of FIG. 2, starting from the center of the hairspring toward the outside, so as to prevent the turns of the blades 1a, 1b from touching each other during the alternating expansion and contraction of the hairspring. FIG. 3 plots one of the two blades 1a, 1b through the formula $r(\theta)=r_0+p(\theta)\times\theta/2\pi$, where r represents the distance from the arbor to the neutral fiber of the blade and $r(\theta=0)=r_0=600$ microns in the case of FIGS. 2 to 4 and $\theta=2\pi N_t$.

[0024] As a variant, the height of the hairspring blade could also be varied.

[0025] In the case of hairsprings made of single-crystal silicon, a material that can be used to produce the hairspring according to the invention, the temperature compensation of the hairspring is achieved by forming, on the surface of the hairspring blades, a layer of amorphous silicon oxide, the thermal coefficient of the Young's modulus of which is of opposite sign to that of single-crystal silicon, as described in EP 1 422 436. This amorphous silicon oxide layer makes it possible to compensate for the thermal coefficient of the Young's modulus whatever the crystallographic orientation of the silicon, namely (100), (111) or (110).

[0026] The number of blades forming the hairspring is not limited to two. As a variant, various other solutions may be envisioned, such as that illustrated in FIG. 5, which is a variant of that of FIG. 1, but which has three blades 1a, 1b and 1c attached, on the one hand, to the bushing 2 and, on the other hand, to the fastening ring 3. The internal and external ends of these blades are angularly offset with respect to one another by an angle of $2\pi/3$. This angular offset will advantageously be $2\pi/n$, where n corresponds to the number of blades.

[0027] Simulations carried out based on the hairsprings of FIGS. 1 and 2 have shown that it ought to be possible for the isochronism of a balance wheel/hairspring resonator fitted with a hairspring according to the present invention to be very substantially improved.

[0028] In the embodiments described hitherto, the blades forming the hairspring are attached to one another via their two respective ends. The embodiment illustrated in FIG. 6 shows a hairspring formed from two blades 1a, 1b attached via only their internal ends to the bushing 2. Their external ends are free, thereby making it possible to pretension the two blades, in one direction or another, so as in particular to adjust the isochronism.

[0029] Other variants using the same concept, namely a hairspring having several angularly offset coplanar blades attached via at least one of their respective homologous ends, can be envisioned.

[0030] Thus, it is possible to have a hairspring comprising four blades, namely two blades 1a, 1b placed between the bushing 2 and an intermediate ring 4, to which their external ends are fastened, and two blades 1c, 1d placed between the intermediate ring and the fastening ring 3. To make the intermediate ring 4 as light as possible, its structure may be apertured so as to reduce its weight as far as possible.

[0031] The internal blades 1a, 1b and the external blades 1c, 1d may all be wound in the same direction, as illustrated in FIG. 7, or the internal blades 1a, 1b may be wound in the opposite direction to that of the external blades 1c, 1d, as illustrated in FIG. 8.

[0032] It is obvious that countless other combinations may be envisioned.

[0033] It is also obvious that the novel design of the hairspring according to the invention does not lend itself to being manufactured using the conventional processes for Nivarox/Parachrom hairsprings.

[0034] In the present case, a process very suitable for the manufacture of the hairspring according to the invention is in particular the one described in EP 1 422 436, already mentioned, which consists in cutting the hairspring, for example by plasma etching, from an {001} single-crystal silicon wafer. The hairspring is temperature-compensated by the formation of a layer of amorphous silicon oxide on the surface of the hairspring blades, for example by a heat treatment.

[0035] It would also be possible to use a quartz single crystal machined in the same way or by chemical machining. Other appropriate materials, adapted to the embodiments for producing a hairspring in a plane, can be used.

[0036] The use of photolithographic processes, such as the UV-LIGA (Lithographie, Galvanisierung und Abformung) process, could also be used to produce this type of hairspring according to the present invention made of a metal alloy.

[0037] The manufacturing process does not form part of the present invention. The nonlimiting examples of processes, listed above by way of example, are merely intended to demonstrate that the technical means for producing the novel type of hairspring according to the invention already exist and that a person skilled in the art has a raft of options for producing this hairspring.

[0038] When the hairspring is referred to as being flat, this is the hairspring as obtained above. However, nothing pre-

cludes locating the embedment points 5 and 6 of the external ends of the blades 1a, 1b outside the plane of the hairspring, especially in the embodiment shown in FIG. 9. Thus, these two embedment points may be respectively located on either side of the plane of the hairspring, so that the two blades 1a, 1b form two symmetrical cones on either side of the plane of the hairspring. This solution has the advantage of preventing the turns of the two blades from touching each other and makes it possible to produce hairsprings of small diameter with a large number of turns. Such a solution therefore constitutes another means of preventing contact between the blades of the hairspring during the alternation of expansions and contractions.

[0039] According to another variant of the invention, the two blades 1a, 1b are made on an SOI (Silicon-On-Insulator) wafer as shown in FIGS. 10a, 10b, which consists of an Si—SiO₂—Si multilayer stack. A blade 1a is etched from the external face of one of the Si layers and the other blade 1b is etched from the external face of the second Si layer. In this case, the internal ends of the two blades are fastened via the intermediate SiO₂ layer 8. The advantage of this embodiment is that it reduces the diameter of the hairspring, as the distance between two adjacent turns is increased. Such an advantage is even more pronounced if the hairspring is extended vertically, as shown in FIG. 10.

[0040] FIG. 11 illustrates another variant of FIGS. 10a, 10b in which the internal ends of the blades 1a, 1b are fastened to the same bushing, whereas their external ends are fastened to the SiO₂ intermediate layer 5.

1. A hairspring for a balance wheel/hairspring resonator, which hairspring comprises n blades, where $n \geq 2$, fastened via at least one of their respective homologous ends are wound in spirals with an angular offset capable of neutralizing the lateral forces likely to be exerted on its central arbor when one of the ends of each blade is moved angularly about said central arbor relative to its other end.

2. The hairspring as claimed in claim 1, wherein the blades are coplanar.

3. The hairspring as claimed in either of the preceding claims, wherein the blades are fastened to each other via their two respective ends.

4. The hairspring as claimed in one of the preceding claims, wherein the pitch of the blades is variable.

5. The hairspring as claimed in one of the preceding claims, wherein the thickness of the blades is variable.

6. The hairspring as claimed in one of the preceding claims, wherein the height of the blades is variable.

7. The hairspring as claimed in one of the preceding claims, which is formed from single-crystal silicon.

8. The hairspring as claimed in claim 7, wherein the single-crystal silicon is covered with a layer of amorphous silicon oxide.

9. The hairspring as claimed in one of claims 1 to 5, which is formed from quartz.

* * * * *